



**2-lamp LED Tube Downlight with T8 retrofit tubes, pendant or surface mounted with vandal resistant lens option**

### SPECIFICATIONS

**Housing:** Extruded aluminum 1/8" thick low-profile housing.

**Lens:** 0.38" THK cast polycarbonate, clear.

**Lumen Output:** 4' tube – 3,500 Lumens. 6' tube – 5,500 Lumens.

**Electrical:** Universal 90-277VAC.

**Operating Range:** -25° to 50°.

**Listings & Certifications:** UL Listed, Wet location, IP65, & IK10 rated with lens.

**Features:** Integral splice compartment.

**Reflector:** .030" thick steel, 94% reflectance.

**Socket Saddle:** 1/8" Aluminum, baked gloss white finish.

**Cable Hinged Vandal Lens:** 0.38" thick flat clear polycarbonate – gasketed.

**Socket:** Single pin stationary one end, single pin telescopic other end.

**Compartment Divider:** 1/8" thick aluminum.

**Housing End Plate:** 3/8" thick machined aluminum, finish to match housing – gasketed.

**Lamp:** (2) LED tube light sources with integral high efficiency drivers, >50,000 hours.

**Screws:** #8-32 (T15) flat head S.S. tamper-resistant countersunk, captive.

**Clevis Hanger:** 3/16" thick aluminum, finish to match housing. Pendant, (2) 1/4-20 x 1" hex head stainless steel bolt. Minimum (2) per unit. Surface, (2) 1/4-20 x 1" hex head stainless steel set screws. Minimum (4) per unit.

**Lamp Clip:** (1) per lamp.

**Fuse:** In-line.

**5 Year Warranty • Made in USA**

### MOUNTING PATTERN

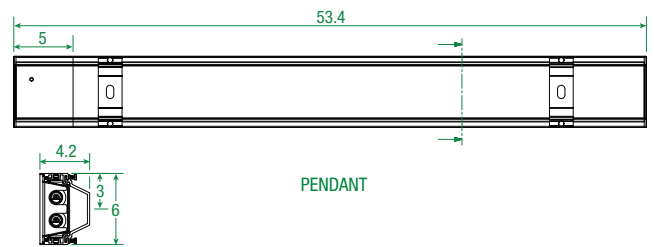
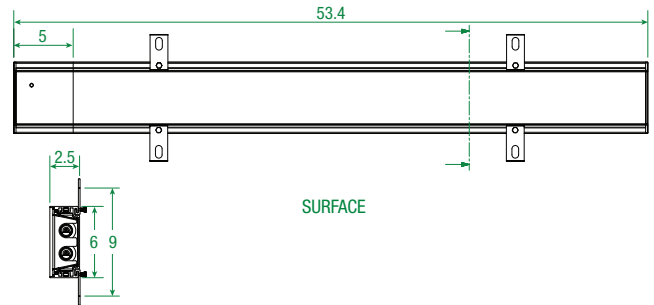

### PHOTOMETRICS

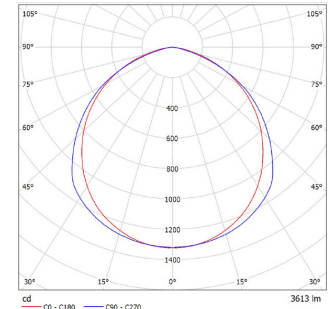

### PROJECT INFORMATION

Date \_\_\_\_\_

Fixture Type \_\_\_\_\_

Project Name \_\_\_\_\_

Catalog Number \_\_\_\_\_

Approved By \_\_\_\_\_

### ORDERING INFORMATION

SERIES	TYPE	COLOR TEMP	LENGTH	PAINT COLOR	POWER INPUTS	MOUNTING	OPTIONS
SL	4098-1	<input type="checkbox"/> 35=3,500K <input type="checkbox"/> 40=4,000K <input type="checkbox"/> 50=5,000K	<input type="checkbox"/> 4=4' <input type="checkbox"/> 6=6'	<input type="checkbox"/> 01=Light Grey <input type="checkbox"/> 02=Argento <input type="checkbox"/> 03=Jet Black <input type="checkbox"/> 06=Platinum	<input type="checkbox"/> UV UV= Universal (90-277 VAC)	<input type="checkbox"/> S=Surface <input type="checkbox"/> P=Pendant	<input type="checkbox"/> V=Vandal & Sealed <input type="checkbox"/> O=Open